

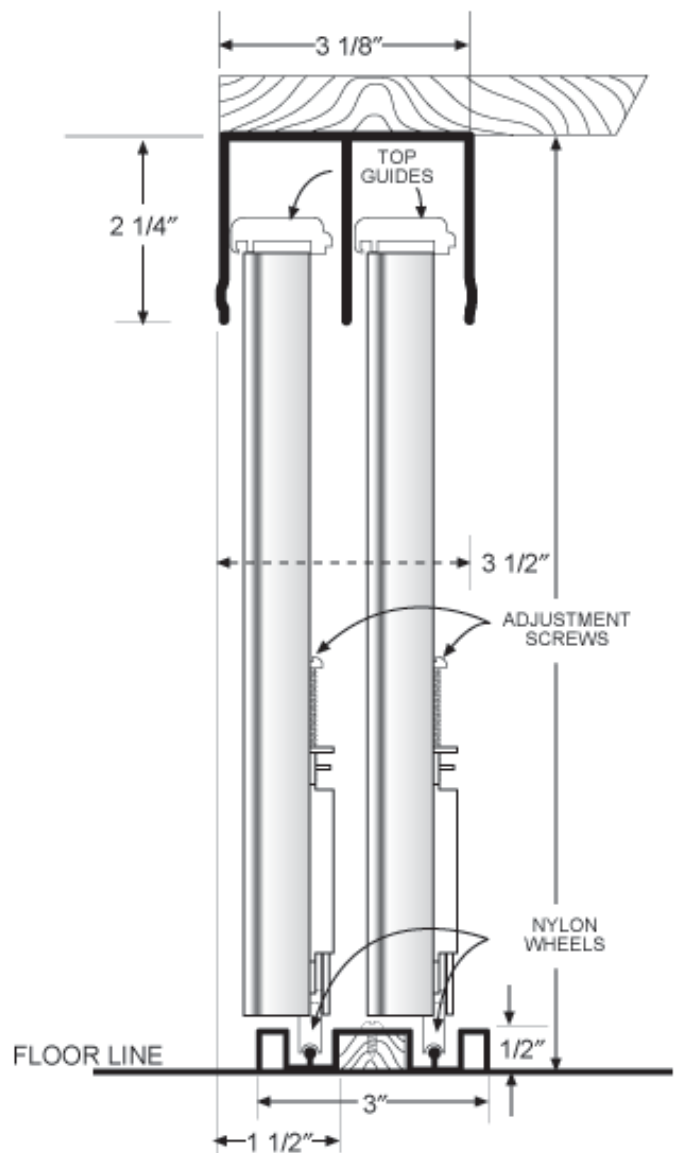

*Innovative Closet Doors Like Nothing Else*

# CDD 5700 PACIFICA

- Sculpted Euro-style Frame of heavy gauge #6063 aluminum Extrusions with integrated Frame side Mold/Handle
- Available in Bright Clear Anodized, Bright Gold Anodized, Satin Clear Anodized, Satin Gold Anodized, Bronze Anodized, Brushed Nickel Anodized and White (High-Gloss) Paint
- White prefinished Hardboard Panel standard
- Panels interchangeable with Tudor™ mirrored Panels
- Top Channel and Bottom Track are extruded aluminum finished to match
- Bottom rolled with jump-proof Track
- One-piece hand-glazed Vinyl, color coordinated to match Frame
- Injection molded Top Guides for smooth operation
- 1 1/2" diameter Wheels with hardened steel Races and 5/32" Ball Bearings in extra-heavy 18-gauge steel Housing
- Full 1" adjustment to fit opening height
- Standard and custom sizes available
- Standard opening width: 48", 60", 72", 84", 96", 108", 120", 144", 168", 192"
- Standard opening height: 81" and 96"



**CDD 5700 Pacifica**

